

NO	QTY	PART NO	DESCRIPTION	SEAL KIT
1	1	21510004	NUT, JAM, HEX, M18-1.50	
2	3	23350087	SPRING, COMPRESSION	X
3	3	23650011	BALL, TUNGSTEN-CARBIDE, 8mm	X
4	4	39051080	O-RING, (10mm X 1)	X
5	1	39051085	O-RING, (63mm X 2)	X
6	2	39051088	O-RING, (8mm X 3)	X
7	1	39053046	SEAL, WIPER, SNAP IN, WED, 36, 94A, AU	X
8	1	39056006	SEAL, STEP, ROD, 36	X
9	1	39056025	SEAL, CAP, PISTON, 63, 90A, AU GRPHT FLD	X
10	2	43068006	PLUG, PORT, HOLLOW HEX, G1/4	
11	1	81400135	PLUNGER, SC, 7MPa, 63B, LH	
12	1	81400155	CAP, LC/SC, 7MPa, 63B	
13	4	81400201	PLUG, MANIFOLD, 7MPa, M10	
14	3	81400204	PIN, STOP, BALL, METRIC, 8mm BALL	X
N/A	N/A	L6014630	KIT, SEAL, SC, 7MPa, 63B	NOTED

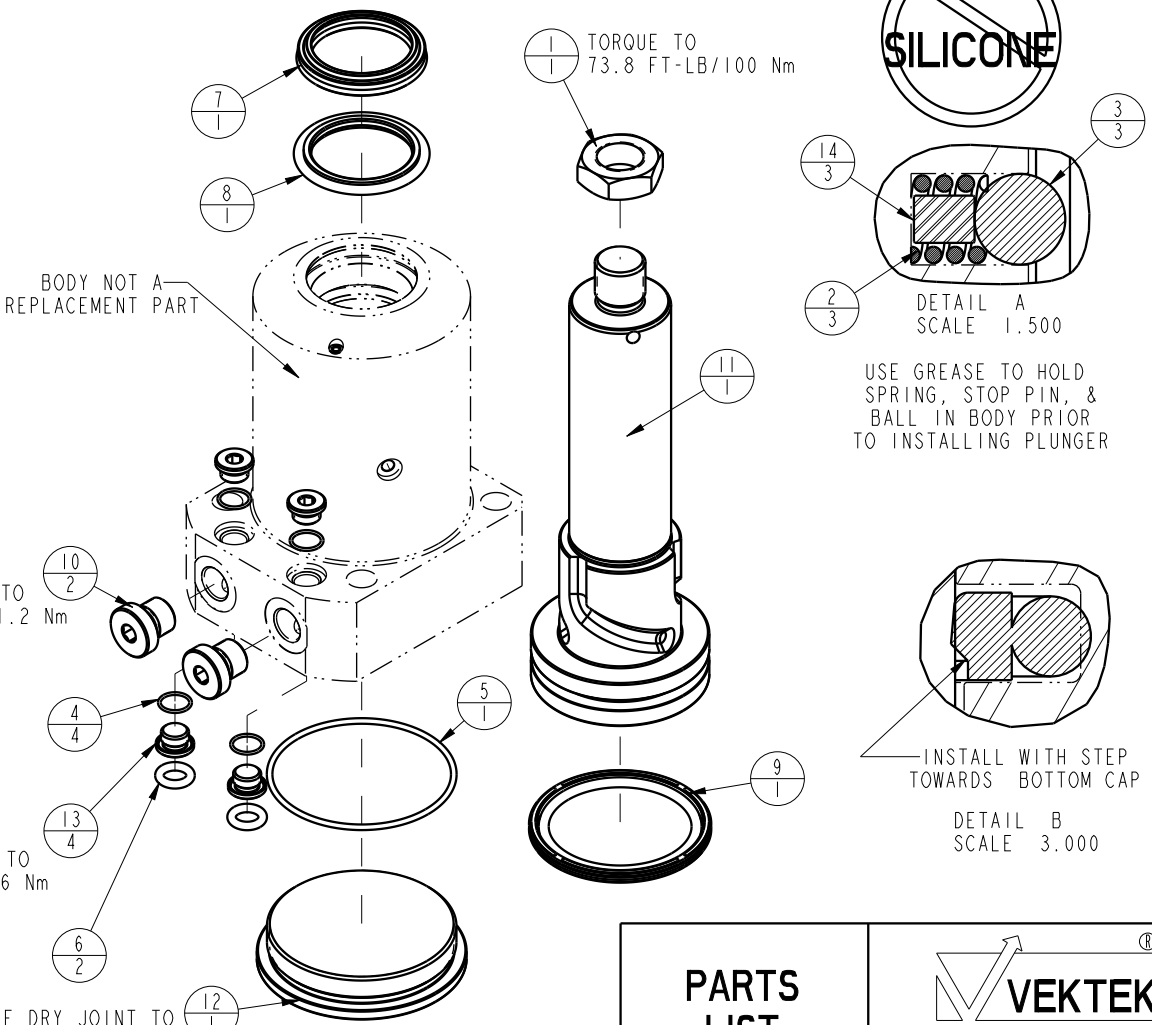
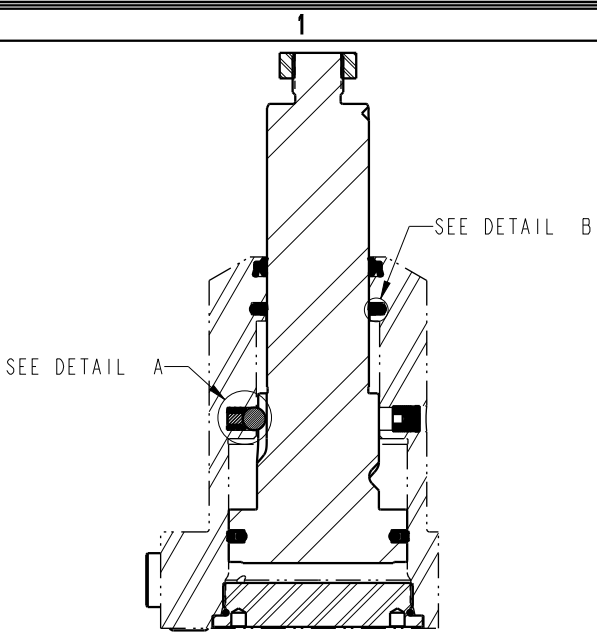

<b>PARTS LIST</b>		
	VEKTEK, INC. 1334 E. SIXTH AVE. P.O. BOX 625 EMPORIA, KS. 66801 U.S.A.	
ASSEMBLIES AFFECTED L1416300L	PARTS LIST, ASSY, SC, BF, 7MPa, 63B, LH	
SIZE A	LPL1420	REV B

B	3273	RELEASE	JDW	08/15/18
REV	IN ACCORDANCE WITH ECN	EFFECTIVE DATE	REVISED BY	DATE
DRW BY:	QMITCHELL	<b>DRAWING STATUS: Released</b>		
DATE:	7-17-13	PRODUCTION APPROVED FOR RELEASED STATUS ONLY		